

IN ACCORDANCE WITH ANSI/APSP/ICC-5 2011, THE INSTALLER IS RESPONSIBLE FOR PLACING ONE SKIMMER FOR EVERY 800 SQUARE FEET OF SURFACE AREA AND ONE RETURN FOR EVERY 300 SQUARE FEET OF SURFACE AREA.

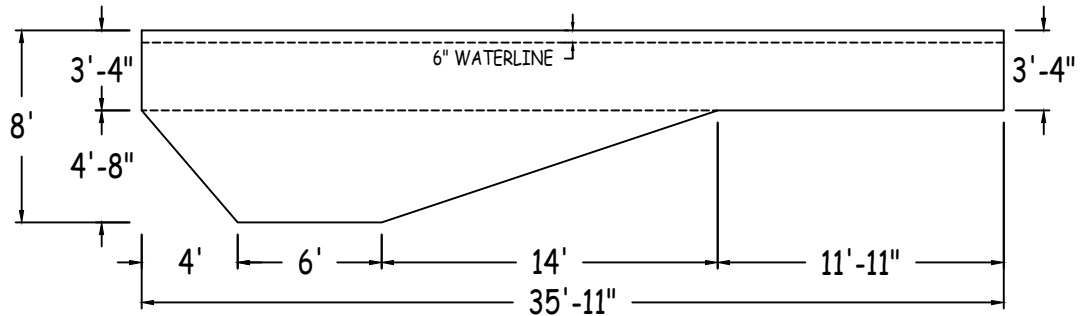
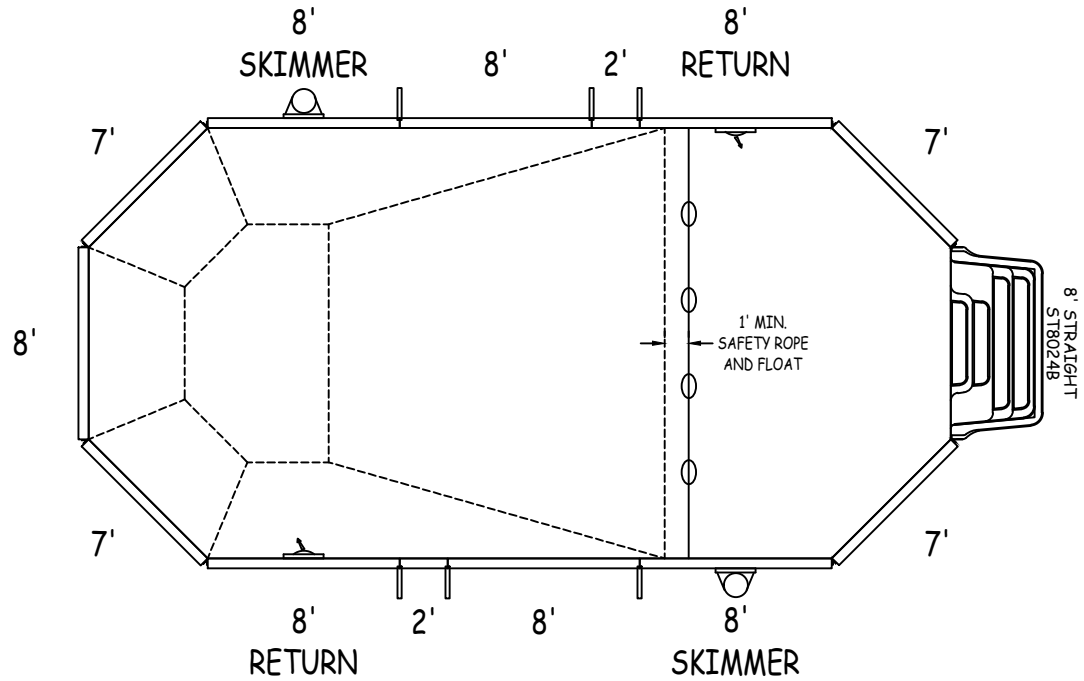
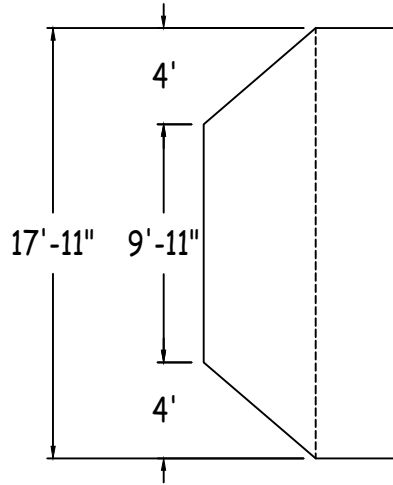

LATHAM STEEL

GRECIAN 17-11 x 35-11

42" STEEL PANELS

PERIMETER: 96'-1" VOLUME (US Gal): 19500

DWG#: 2024-SPL-08614

SURFACE (ft²): 594 VOLUME (Liters): 73800

KIT#: CUSTOMKIT

LINER (ft²): 644 DATE: 3/6/2024 DSR:

COVER (ft²): 755

SCALE: 1/8" = 1'-0"



DIVING/SLIDING EQUIPMENT SHALL BE DESIGNED FOR SWIMMING POOLS AND SHALL BE INSTALLED IN ACCORDANCE WITH THE DIVING/SLIDING EQUIPMENT MANUFACTURER'S SPECIFICATIONS. PLEASE CONTACT THE DIVING/SLIDING EQUIPMENT MANUFACTURER FOR THEIR SPECIFICATIONS.

ALL ASPECTS OF THIS DRAWING COMPLIES WITH ANSI/APSP/ICC-5 2011 AND 2015 ISPSC

CUSTOMER: SCP/OLIVE BRANCH

JOB NAME: USSE00S1836-16



Diagonals	2 to 7	33'-6 3/4"
S1toS2	2 to 8	31'-4 1/4"
H1toH2	3 to 4	8'-0"
S1toH1	3 to 5	13'-10 1/2"
S2toH2	3 to 6	33'-6 3/4"
S1toH2	3 to 7	36'-9 1/2"
H1toS2	3 to 8	35'-11"
1 to 2	4 to 5	7'- 1/4"
1 to 3	4 to 6	31'-4 1/4"
1 to 4	4 to 7	35'-11"
1 to 5	4 to 8	36'-9 1/2"
1 to 6	5 to 6	26'-0"
1 to 7	5 to 7	31'-4 1/4"
1 to 8	5 to 8	33'-6 3/4"
2 to 3	6 to 7	7'- 1/4"
2 to 4	6 to 8	13'-10 1/2"
2 to 5	7 to 8	8'-0"
2 to 6	31'-7"	

		Base
Part number	Description	QTY
ST0960002X	8'	3
ST0960002*	8' SKIMMER	2
ST0960002*	8' RETURN	2
ST0840002X	7'	4
ST0240000X	2'	2
Brace	Brace	6
IPC-AB45	CONNECTOR CNR ANGLE 45D 42"	6
IPC-AB45-STP	CONNECTOR CNR ANGLE STEP 45D 42"	2
IPC-STKPK25	REBAR STAKE 18" 25PC	1
IPC-HDWSTRT150	BOLT STR 3/8-16X1" C/W NUT 150PC	1
IPC-HDW-PK45	BOLT 45DEG 3/8-16X1-1/2" 72PC	1
ST8024B	THICKSHEET STEP STR SIT N STEP 8'	1

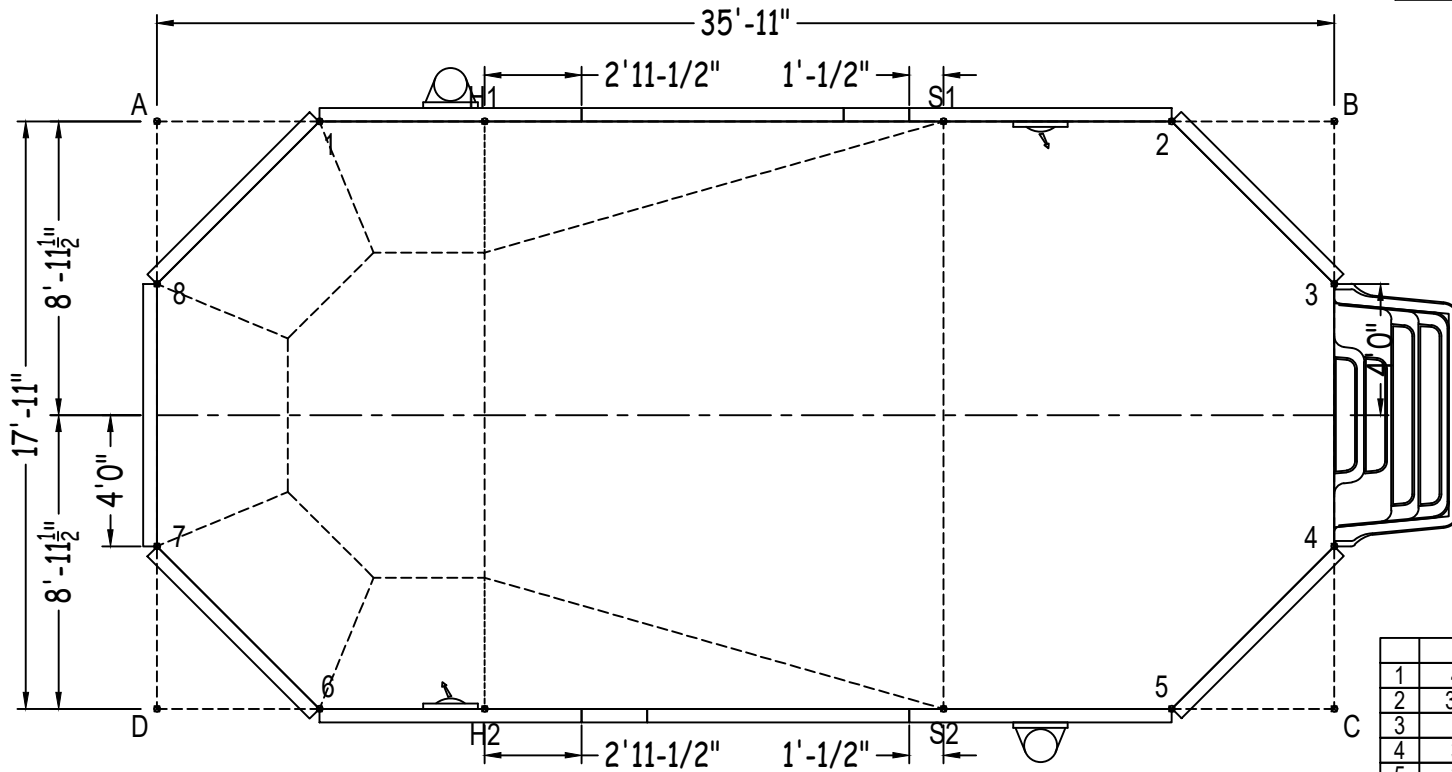

	A	B	C	D
1	4'-11 1/2"	30'-11 1/2"	35'-9 1/4"	18'-7"
2	30'-11 1/2"	4'-11 1/2"	18'-7"	35'-9 1/4"
3	36'-3"	4'-11 1/2"	12'-11 1/2"	38'-2 1/4"
4	38'-2 1/4"	12'-11 1/2"	4'-11 1/2"	36'-3"
5	35'-9 1/4"	18'-7"	4'-11 1/2"	30'-11 1/2"
6	18'-7"	35'-9 1/4"	30'-11 1/2"	4'-11 1/2"
7	12'-11 1/2"	38'-2 1/4"	36'-3"	4'-11 1/2"
8	4'-11 1/2"	36'-3"	38'-2 1/4"	12'-11 1/2"
S2	29'-11 1/2"	21'-6 1/4"	11'-11"	24'-0"
S1	24'-0"	11'-11"	21'-6 1/4"	29'-11 1/2"
H2	20'-6 1/4"	31'-6"	25'-11"	10'-0"
H1	10'-0"	25'-11"	31'-6"	20'-6 1/4"
A	-	35'-11"	40'-1 3/4"	17'-11"